

Lecture 1

Thévenin Equivalent Circuits

ELECTRICAL ENGINEERING: PRINCIPLES AND APPLICATIONS, Fourth Edition, by Allan R. Hambley, ©2008 Pearson Education, Inc.

Thévenin Equivalent Circuits

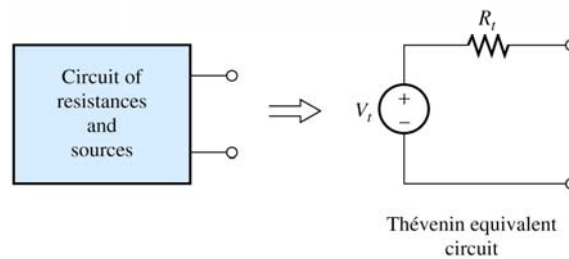

Figure 2.40 A two-terminal circuit consisting of resistances and sources can be replaced by a Thévenin equivalent circuit.

ELECTRICAL ENGINEERING: PRINCIPLES AND APPLICATIONS, Fourth Edition, by Allan R. Hambley, ©2008 Pearson Education, Inc.

Thévenin Equivalent Circuits

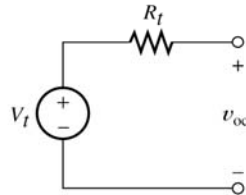

Figure 2.41 Thévenin equivalent circuit with open-circuited terminals. The open-circuit voltage v_{oc} is equal to the Thévenin voltage V_t .

$$V_t = v_{oc}$$

ELECTRICAL ENGINEERING: PRINCIPLES AND APPLICATIONS, Fourth Edition, by Allan R. Hambley, ©2008 Pearson Education, Inc.

Thévenin Equivalent Circuits

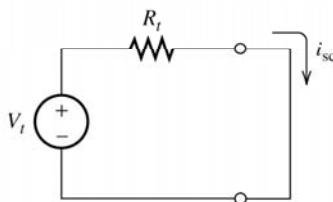
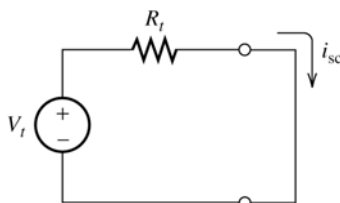

Figure 2.42 Thévenin equivalent circuit with short-circuited terminals. The short-circuit current is $i_{sc} = V_t/R_t$.

$$i_{sc} = \frac{V_t}{R_t}$$

ELECTRICAL ENGINEERING: PRINCIPLES AND APPLICATIONS, Fourth Edition, by Allan R. Hambley, ©2008 Pearson Education, Inc.

Thévenin Equivalent Circuits



$$R_t = \frac{V_{oc}}{i_{sc}}$$

ELECTRICAL ENGINEERING: PRINCIPLES AND APPLICATIONS, Fourth Edition, by Allan R. Hambley, ©2008 Pearson Education, Inc.

Find the Thevenin Equivalent Circuit

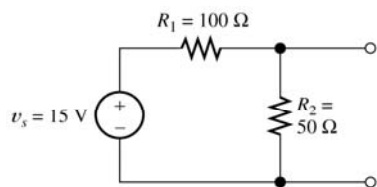

(a) Original circuit

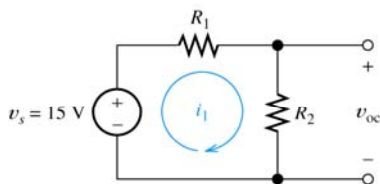

(b) Analysis with an open circuit

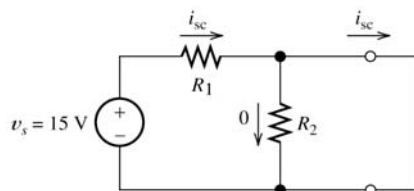

(c) Analysis with a short circuit

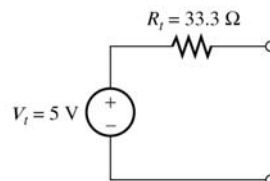

(d) Thévenin equivalent

Figure 2.43 Circuit for Example 2.14.

ELECTRICAL ENGINEERING: PRINCIPLES AND APPLICATIONS, Fourth Edition, by Allan R. Hambley, ©2008 Pearson Education, Inc.

Find the Thevenin Equivalent Circuit

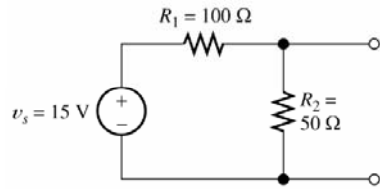

(a) Original circuit

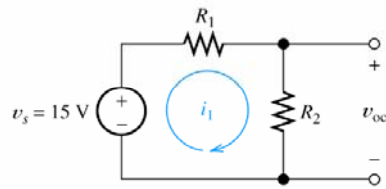

(b) Analysis with an open circuit

Use voltage divider formed by R_1 and R_2 to find v_{oc} :

$$v_{oc} = \frac{R_2}{R_1 + R_2} v_s = \frac{50}{100 + 50} 15V = 5V$$

ELECTRICAL ENGINEERING: PRINCIPLES AND APPLICATIONS, Fourth Edition, by Allan R. Hambley, ©2008 Pearson Education, Inc.

Find the Thevenin Equivalent Circuit

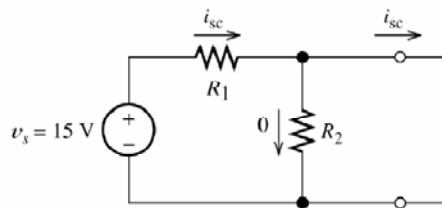

$$i_{sc} = \frac{v_s}{R_1} = \frac{15V}{100\Omega} = 0.15A$$

ELECTRICAL ENGINEERING: PRINCIPLES AND APPLICATIONS, Fourth Edition, by Allan R. Hambley, ©2008 Pearson Education, Inc.

Find the Thevenin Equivalent Circuit

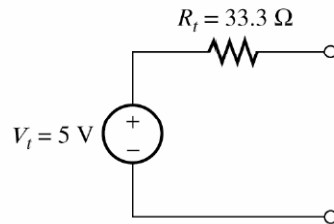

$$R_t = \frac{v_{oc}}{i_{sc}} = \frac{5V}{0.15A} = 33.3\Omega$$

ELECTRICAL ENGINEERING: PRINCIPLES AND APPLICATIONS, Fourth Edition, by Allan R. Hambley, ©2008 Pearson Education, Inc.

Find the Thevenin Equivalent Circuit

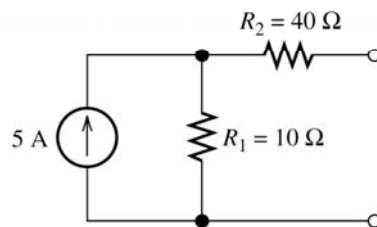
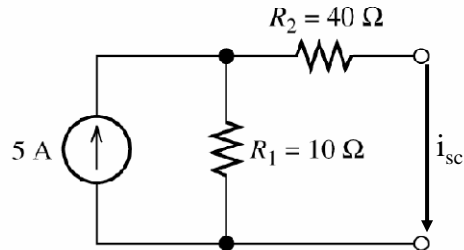

Figure 2.44 Circuit for Exercise 2.22.

$$v_{oc} = (5A)(10\Omega) = 50V$$

ELECTRICAL ENGINEERING: PRINCIPLES AND APPLICATIONS, Fourth Edition, by Allan R. Hambley, ©2008 Pearson Education, Inc.

Find the Thevenin Equivalent Circuit



Use current divider to find i_{sc} :

$$i_{sc} = \frac{R_1}{R_1 + R_2} 5A = \frac{10}{10 + 40} 5A = 1A$$

$$R_t = \frac{v_{oc}}{i_{sc}} = \frac{50V}{1A} = 50\Omega$$

ELECTRICAL ENGINEERING: PRINCIPLES AND APPLICATIONS, Fourth Edition, by Allan R. Hambley, ©2008 Pearson Education, Inc.

Find the Thevenin Equivalent Circuit

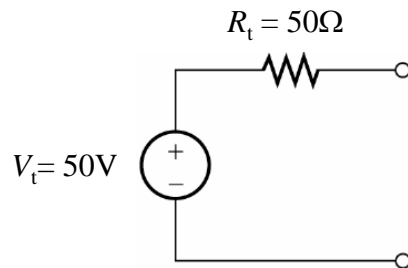

ELECTRICAL ENGINEERING: PRINCIPLES AND APPLICATIONS, Fourth Edition, by Allan R. Hambley, ©2008 Pearson Education, Inc.

Finding the Thévenin Resistance Directly

We can find the Thévenin resistance by zeroing the sources in the original network and then computing the resistance between the terminals.

When zeroing a voltage source, it becomes a short circuit. When zeroing a current source, it becomes an open circuit.

ELECTRICAL ENGINEERING: PRINCIPLES AND APPLICATIONS, Fourth Edition, by Allan R. Hambley, ©2008 Pearson Education, Inc.

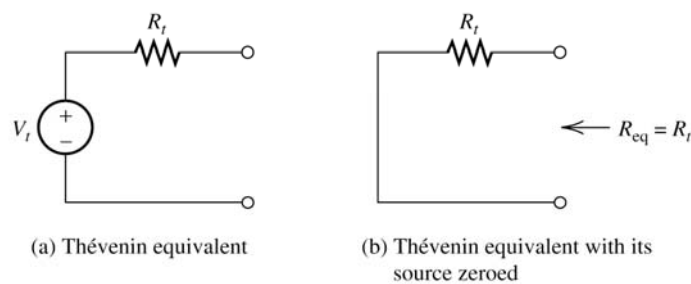

Figure 2.45 When the source is zeroed, the resistance seen from the circuit terminals is equal to the Thévenin resistance.

ELECTRICAL ENGINEERING: PRINCIPLES AND APPLICATIONS, Fourth Edition, by Allan R. Hambley, ©2008 Pearson Education, Inc.

Find the Thevenin Equivalent

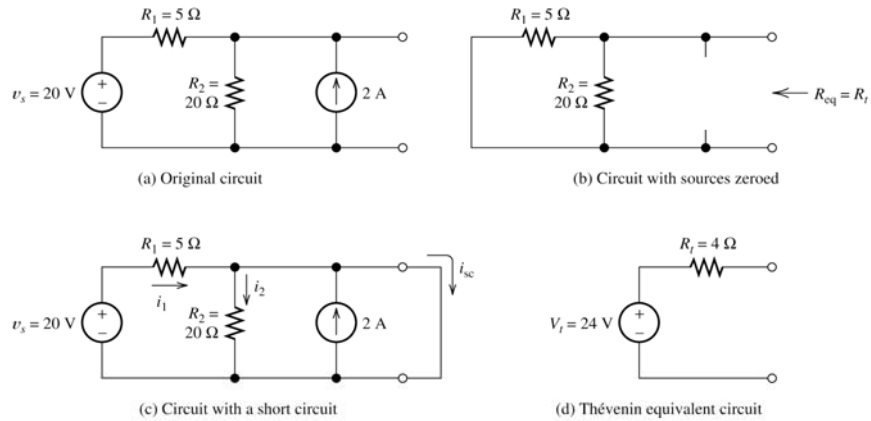
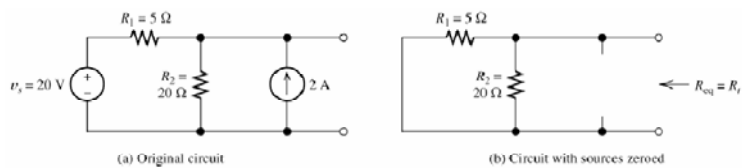

Figure 2.46 Circuit for Example 2.15.

ELECTRICAL ENGINEERING: PRINCIPLES AND APPLICATIONS, Fourth Edition, by Allan R. Hambley, ©2008 Pearson Education, Inc.

Find the Thevenin Equivalent



$$R_{eq} = R_t = \frac{R_1 R_2}{R_1 + R_2} = \frac{100}{25} = 4\Omega$$

ELECTRICAL ENGINEERING: PRINCIPLES AND APPLICATIONS, Fourth Edition, by Allan R. Hambley, ©2008 Pearson Education, Inc.

Find the Thevenin Equivalent

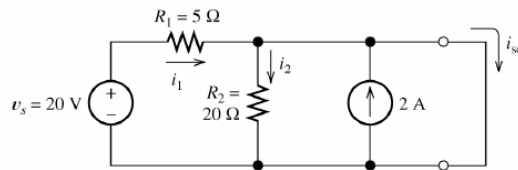

(c) Circuit with a short circuit

$$i_2 = 0$$

$$i_1 = \frac{20V}{5\Omega} = 4A$$

$$i_{sc} = i_1 + 2A = 4A + 2A = 6A$$

ELECTRICAL ENGINEERING: PRINCIPLES AND APPLICATIONS, Fourth Edition, by Allan R. Hambley, ©2008 Pearson Education, Inc.

Find the Thevenin Equivalent

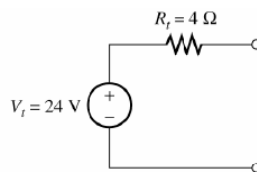

$$V_t = R_t i_{sc} = (4\Omega)(6A) = 24V$$

ELECTRICAL ENGINEERING: PRINCIPLES AND APPLICATIONS, Fourth Edition, by Allan R. Hambley, ©2008 Pearson Education, Inc.

Find the Thevenin Resistance

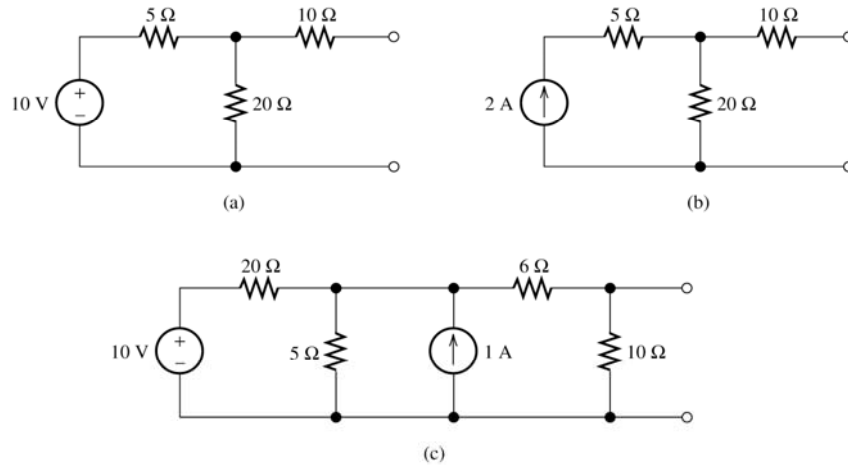
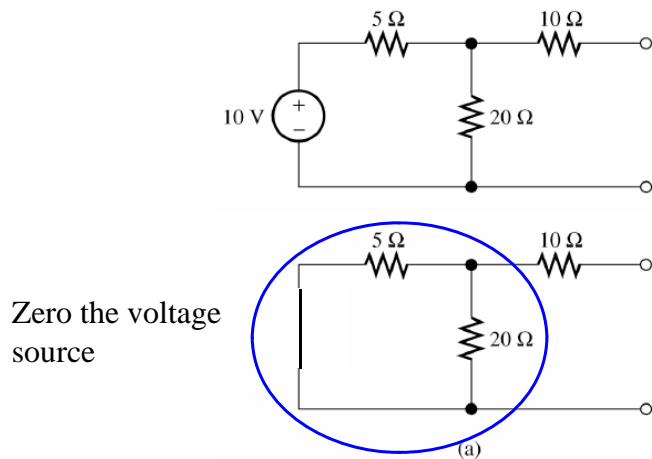

Figure 2.47 Circuits for Exercise 2.24.

ELECTRICAL ENGINEERING: PRINCIPLES AND APPLICATIONS, Fourth Edition, by Allan R. Hambley, ©2008 Pearson Education, Inc.

Find the Thevenin Resistance



$$R_t = 10 + \frac{(5)(20)}{5 + 20} = 10 + 4 = 14\Omega$$

ELECTRICAL ENGINEERING: PRINCIPLES AND APPLICATIONS, Fourth Edition, by Allan R. Hambley, ©2008 Pearson Education, Inc.

Find the Thevenin Resistance

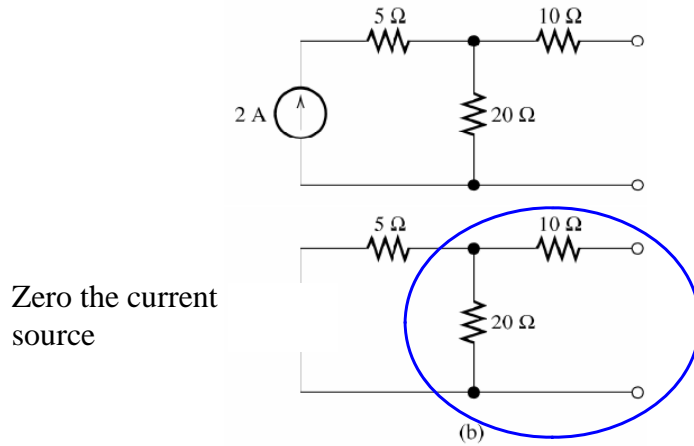

$$R_t = 10 + 20 = 30\Omega$$

ELECTRICAL ENGINEERING: PRINCIPLES AND APPLICATIONS, Fourth Edition, by Allan R. Hambley, ©2008 Pearson Education, Inc.

Find the Thevenin Resistance

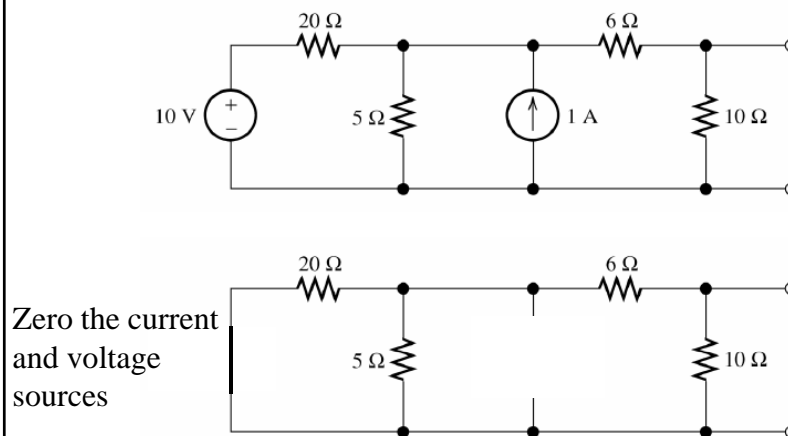

ELECTRICAL ENGINEERING: PRINCIPLES AND APPLICATIONS, Fourth Edition, by Allan R. Hambley, ©2008 Pearson Education, Inc.

Find the Thevenin Resistance

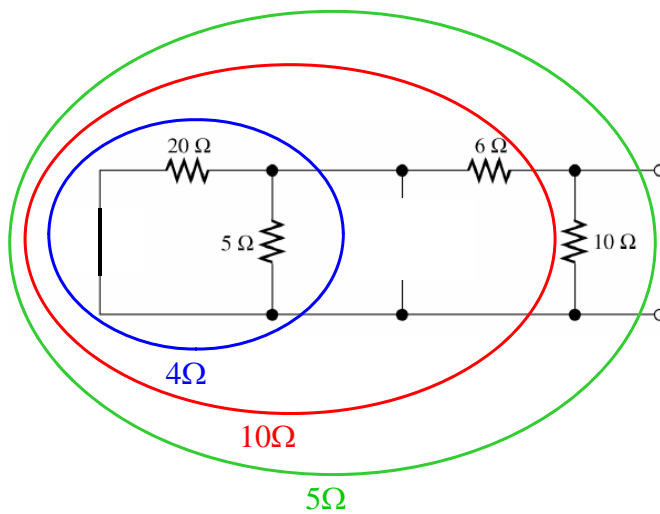

ELECTRICAL ENGINEERING: PRINCIPLES AND APPLICATIONS, Fourth Edition, by Allan R. Hambley, ©2008 Pearson Education, Inc.

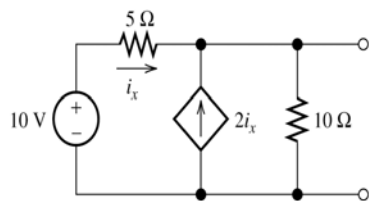

(a) Original circuit

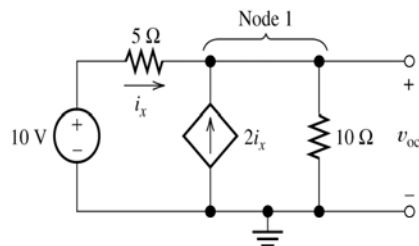

(b) Circuit with an open circuit

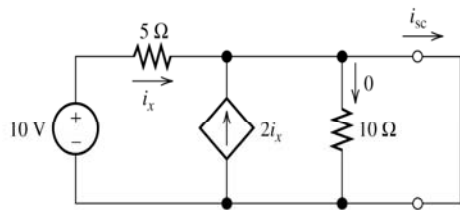

(c) Circuit with a short circuit

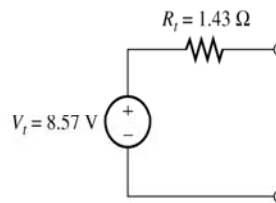

(d) Thévenin equivalent

Figure 2.48 Circuit for Example 2.16.

ELECTRICAL ENGINEERING: PRINCIPLES AND APPLICATIONS, Fourth Edition, by Allan R. Hambley, ©2008 Pearson Education, Inc.

Thevenin Equivalent with a Dependent Source

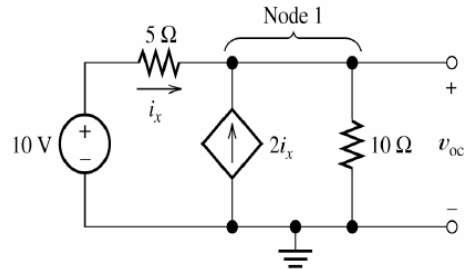

(b) Circuit with an open circuit

$$KCL \text{ at Node 1: } i_x + 2i_x = \frac{v_{oc}}{10} = 3i_x$$

$$i_x = \frac{10 - v_{oc}}{5} \rightarrow 3 \frac{10 - v_{oc}}{5} = \frac{v_{oc}}{10} \rightarrow v_{oc} = 8.57V$$

ELECTRICAL ENGINEERING: PRINCIPLES AND APPLICATIONS, Fourth Edition, by Allan R. Hambley, ©2008 Pearson Education, Inc.

Thevenin Equivalent with a Dependent Source

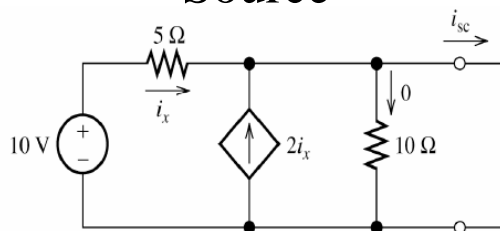

(c) Circuit with a short circuit

$$i_x + 2i_x = 3i_x = i_{sc}$$

$$i_x = \frac{10V}{5\Omega} = 2A \rightarrow i_{sc} = 6A$$

$$R_t = \frac{V_t}{i_{sc}} = \frac{8.57V}{6A} = 1.43\Omega$$

ELECTRICAL ENGINEERING: PRINCIPLES AND APPLICATIONS, Fourth Edition, by Allan R. Hambley, ©2008 Pearson Education, Inc.

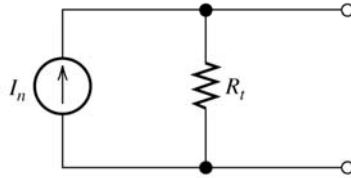

Figure 2.49 The Norton equivalent circuit consists of an independent current source I_n in parallel with the Thévenin resistance R_t .

ELECTRICAL ENGINEERING: PRINCIPLES AND APPLICATIONS, Fourth Edition, by Allan R. Hambley, ©2008 Pearson Education, Inc.

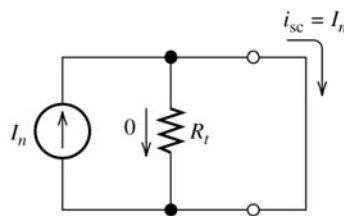

Figure 2.50 The Norton equivalent circuit with a short circuit across its terminals.

$$I_n = i_{sc}$$

ELECTRICAL ENGINEERING: PRINCIPLES AND APPLICATIONS, Fourth Edition, by Allan R. Hambley, ©2008 Pearson Education, Inc.

Step-by-step Thévenin/Norton-Equivalent- Circuit Analysis

1. Perform two of these:
 - a. Determine the open-circuit voltage $V_t = v_{oc}$.
 - b. Determine the short-circuit current $I_n = i_{sc}$.
 - c. Zero the sources and find the Thévenin resistance R_t looking back into the terminals.

ELECTRICAL ENGINEERING: PRINCIPLES AND APPLICATIONS, Fourth Edition, by Allan R. Hambley, ©2008 Pearson Education, Inc.

2. Use the equation $V_t = R_t I_n$ to compute the remaining value.
3. The Thévenin equivalent consists of a voltage source V_t in series with R_t .
4. The Norton equivalent consists of a current source I_n in parallel with R_t .

ELECTRICAL ENGINEERING: PRINCIPLES AND APPLICATIONS, Fourth Edition, by Allan R. Hambley, ©2008 Pearson Education, Inc.

Find the Norton Equivalent

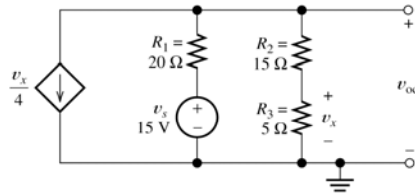

(a) Original circuit under open-circuit conditions



(b) Circuit with a short circuit

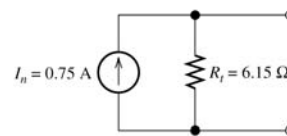

(c) Norton equivalent circuit

Figure 2.51 Circuit of Example 2.17.

ELECTRICAL ENGINEERING: PRINCIPLES AND APPLICATIONS, Fourth Edition, by Allan R. Hambley, ©2008 Pearson Education, Inc.

Find the Norton Equivalent

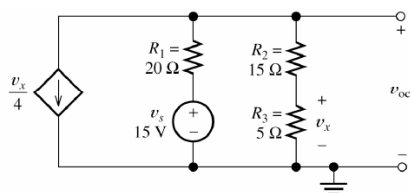

(a) Original circuit under open-circuit conditions

$$KCL: \frac{v_x}{4} + \frac{v_{oc} - 15}{R_1} + \frac{v_{oc}}{R_2 + R_3} = 0$$

$$\text{Voltage divider: } v_x = \frac{R_3}{R_2 + R_3} v_{oc} = 0.25v_{oc}$$

$$\frac{0.25v_{oc}}{4} + \frac{v_{oc} - 15}{R_1} + \frac{v_{oc}}{R_2 + R_3} = 0 \rightarrow v_{oc} = 4.62V$$

ELECTRICAL ENGINEERING: PRINCIPLES AND APPLICATIONS, Fourth Edition, by Allan R. Hambley, ©2008 Pearson Education, Inc.

Find the Norton Equivalent

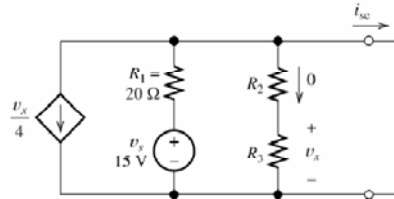

(b) Circuit with a short circuit

$$v_x = 0$$

$$i_{sc} R_1 - 15V = 0 \rightarrow i_{sc} = \frac{15V}{20\Omega} = 0.75A$$

$$R_t = \frac{v_{oc}}{i_{sc}} = \frac{4.62V}{0.75A} = 6.15\Omega$$

ELECTRICAL ENGINEERING: PRINCIPLES AND APPLICATIONS, Fourth Edition, by Allan R. Hambley, ©2008 Pearson Education, Inc.

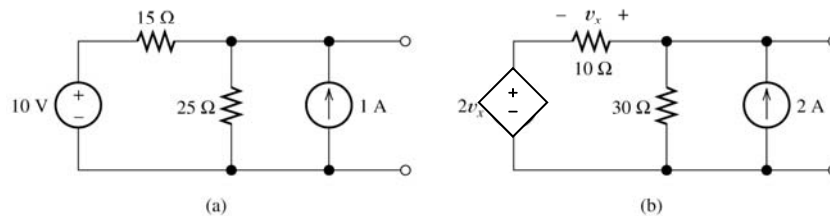
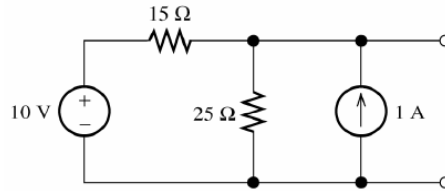

Figure 2.52 Circuits for Exercise 2.25.

ELECTRICAL ENGINEERING: PRINCIPLES AND APPLICATIONS, Fourth Edition, by Allan R. Hambley, ©2008 Pearson Education, Inc.

Find the Norton Equivalent



(a)

$$\frac{v_{oc} - 10}{15} + \frac{v_{oc}}{25} - 1 = 0 \rightarrow v_{oc} = \frac{125}{8} = 15.63A$$

ELECTRICAL ENGINEERING: PRINCIPLES AND APPLICATIONS, Fourth Edition, by Allan R. Hambley, ©2008 Pearson Education, Inc.

Find the Norton Equivalent

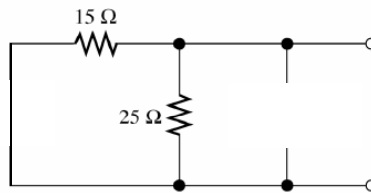

(a)

To find R_t zero the sources:

$$R_t = \frac{(15\Omega)(25\Omega)}{15\Omega + 25\Omega} = 9.38\Omega$$

$$i_{sc} = \frac{V_t}{R_t} = \frac{15.63V}{9.38\Omega} = 1.67A$$

ELECTRICAL ENGINEERING: PRINCIPLES AND APPLICATIONS, Fourth Edition, by Allan R. Hambley, ©2008 Pearson Education, Inc.

Find the Norton Equivalent

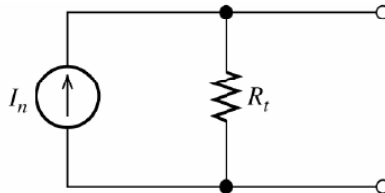

$$R_t = 9.38\Omega$$

$$i_n = 1.67A$$

ELECTRICAL ENGINEERING: PRINCIPLES AND APPLICATIONS, Fourth Edition, by Allan R. Hambley, ©2008 Pearson Education, Inc.

Find the Norton Equivalent

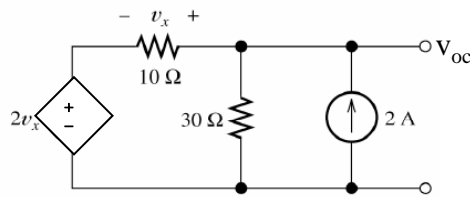

(b)

$$KVL: v_{oc} - 2v_x - v_x = 0 \rightarrow v_{oc} = 3v_x$$

$$KCL: \frac{v_{oc} - 2v_x}{10} + \frac{v_{oc}}{30} - 2 = 0 \rightarrow v_{oc} = 30V$$

ELECTRICAL ENGINEERING: PRINCIPLES AND APPLICATIONS, Fourth Edition, by Allan R. Hambley, ©2008 Pearson Education, Inc.

Find the Norton Equivalent

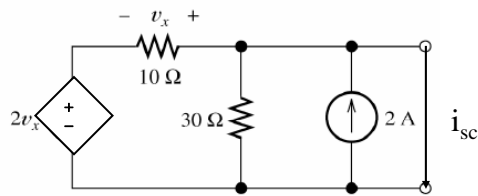

(b)

$$KVL: -2v_x - v_x = 0 \rightarrow v_x = 0$$

$$KCL: \frac{0 - 2v_x}{10} + i_{sc} - 2 = 0 \rightarrow i_{sc} = 2A = i_n$$

ELECTRICAL ENGINEERING: PRINCIPLES AND APPLICATIONS, Fourth Edition, by Allan R. Hambley, ©2008 Pearson Education, Inc.

Find the Norton Equivalent

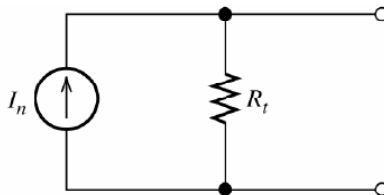

$$i_n = 2A$$

$$R_t = \frac{v_{oc}}{i_{sc}} = \frac{30V}{2A} = 15\Omega$$

ELECTRICAL ENGINEERING: PRINCIPLES AND APPLICATIONS, Fourth Edition, by Allan R. Hambley, ©2008 Pearson Education, Inc.

Source Transformations

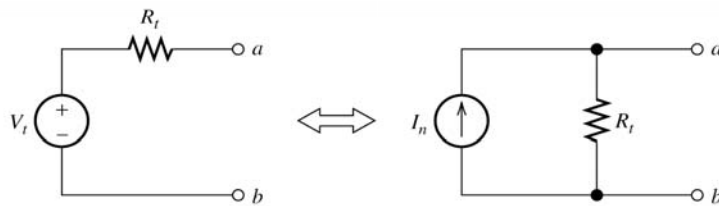

Figure 2.53 A voltage source in series with a resistance is externally equivalent to a current source in parallel with the resistance, provided that $I_n = V_t/R_t$.

ELECTRICAL ENGINEERING: PRINCIPLES AND APPLICATIONS, Fourth Edition, by Allan R. Hambley, ©2008 Pearson Education, Inc.

Source Transformations

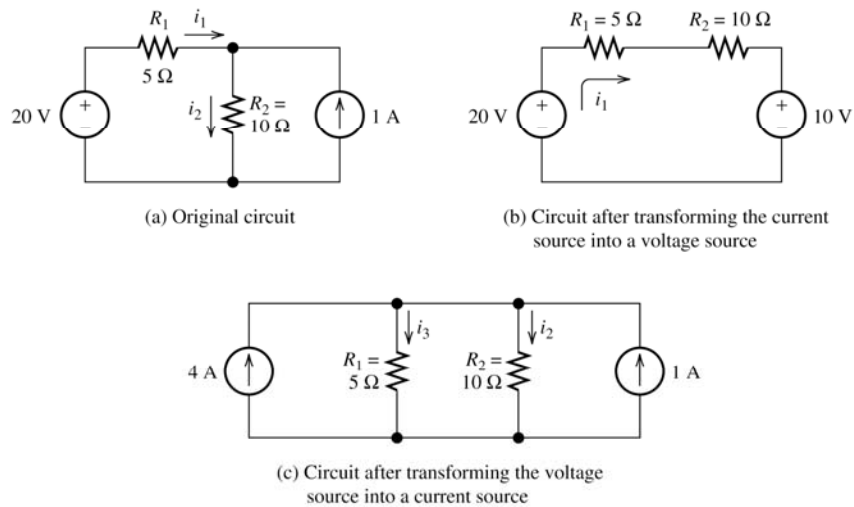
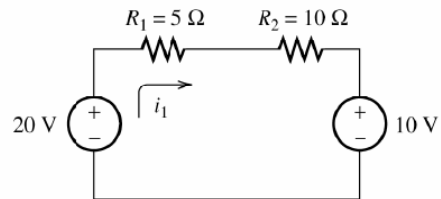

Figure 2.54 Circuit for Example 2.18.

ELECTRICAL ENGINEERING: PRINCIPLES AND APPLICATIONS, Fourth Edition, by Allan R. Hambley, ©2008 Pearson Education, Inc.

Source Transformations



(b) Circuit after transforming the current source into a voltage source

$$V_t = i_n R_t = (1A)(10\Omega) = 10V$$

$$R_1 i_1 + R_2 i_1 + 10 - 20 = 0 \rightarrow i_1 = \frac{10}{R_1 + R_2} = 0.667A$$

ELECTRICAL ENGINEERING: PRINCIPLES AND APPLICATIONS, Fourth Edition, by Allan R. Hambley, ©2008 Pearson Education, Inc.

Source Transformations

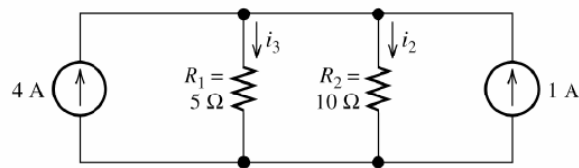

(c) Circuit after transforming the voltage source into a current source

$$i_n = \frac{V_t}{R_t} = \frac{20V}{5\Omega} = 4A$$

$$i_2 + i_3 = 5A$$

$$\text{Current divider: } i_2 = \frac{R_1}{R_1 + R_2} 5A = \frac{5}{5 + 10} 5A = 1.667A$$

ELECTRICAL ENGINEERING: PRINCIPLES AND APPLICATIONS, Fourth Edition, by Allan R. Hambley, ©2008 Pearson Education, Inc.

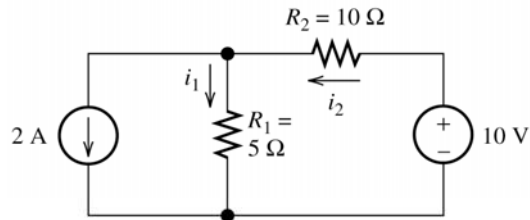
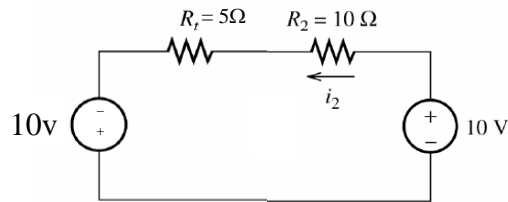

Figure 2.55 Circuit for Exercise 2.26.

Transform the Norton equivalent into a Thevenin equivalent with $V_t = (2A)(5\Omega) = 10V$, $R_t = 5\Omega$

Note the reference direction for the current gives the polarity for the voltage source!



ELECTRICAL ENGINEERING: PRINCIPLES AND APPLICATIONS, Fourth Edition, by Allan R. Hambley, ©2008 Pearson Education, Inc.

Source Transformations

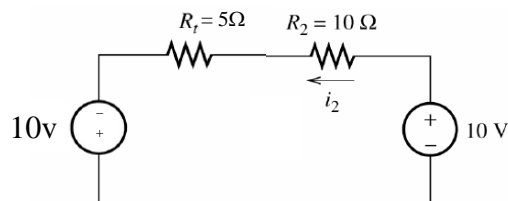

$$KVL: -10V + i_2 R_2 + i_2 R_t - 10V = i_2 10 + i_2 5 - 20V = 0$$

$$i_2 = \frac{20V}{10+5} = 1.33A$$

ELECTRICAL ENGINEERING: PRINCIPLES AND APPLICATIONS, Fourth Edition, by Allan R. Hambley, ©2008 Pearson Education, Inc.

Source Transformations

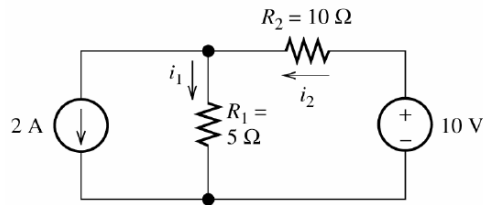

$$i_2 = i_1 + 2A \rightarrow i_1 = i_2 - 2A = 1.333 - 2A = -0.667A$$

ELECTRICAL ENGINEERING: PRINCIPLES AND APPLICATIONS, Fourth Edition, by Allan R. Hambley, ©2008 Pearson Education, Inc.

SUPERPOSITION PRINCIPLE

The **superposition principle** states that the total response is the sum of the responses to each of the independent sources acting individually. In equation form, this is

$$r_T = r_1 + r_2 + \cdots + r_n$$

ELECTRICAL ENGINEERING: PRINCIPLES AND APPLICATIONS, Fourth Edition, by Allan R. Hambley, ©2008 Pearson Education, Inc.

Superposition Principle

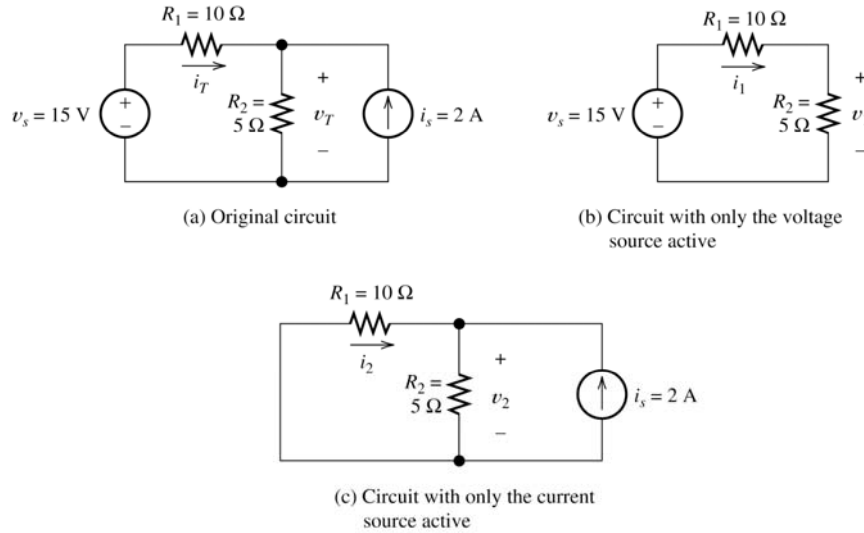
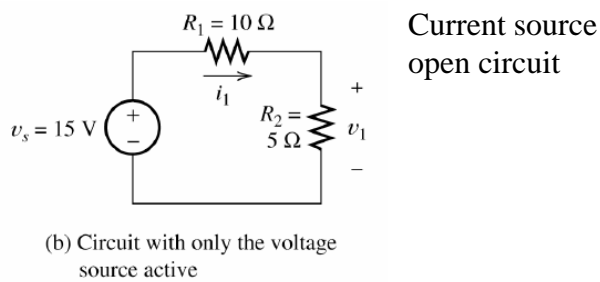

Figure 2.60 Circuit for Example 2.20 and Exercise 2.27.

ELECTRICAL ENGINEERING: PRINCIPLES AND APPLICATIONS, Fourth Edition, by Allan R. Hambley, ©2008 Pearson Education, Inc.

Superposition Principle



$$v_1 = \frac{R_2}{R_1 + R_2} v_s = \frac{5}{5 + 10} 15V = 5V$$

ELECTRICAL ENGINEERING: PRINCIPLES AND APPLICATIONS, Fourth Edition, by Allan R. Hambley, ©2008 Pearson Education, Inc.

Superposition Principle

Voltage source
short circuit

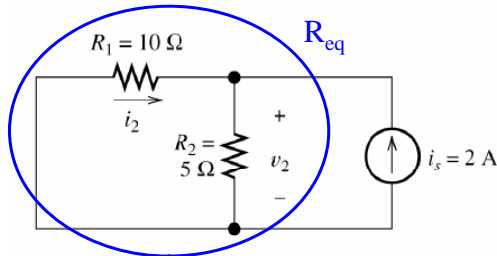

(c) Circuit with only the current source active

$$v_2 = i_s R_{eq} = i_s \frac{R_1 R_2}{R_1 + R_2} = (2A) \frac{(10)(5)}{10 + 5} = (2A)(3.33\Omega) = 6.66V$$

$$v_T = v_1 + v_2 = 5V + 6.66V = 11.66V$$

ELECTRICAL ENGINEERING: PRINCIPLES AND APPLICATIONS, Fourth Edition, by Allan R. Hambley, ©2008 Pearson Education, Inc.

Superposition Principle

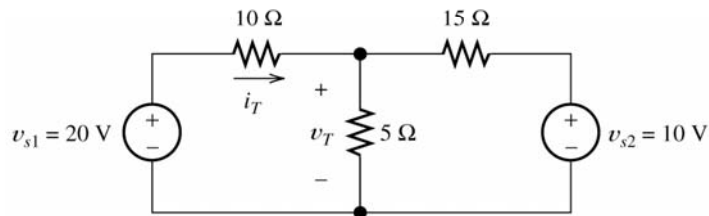
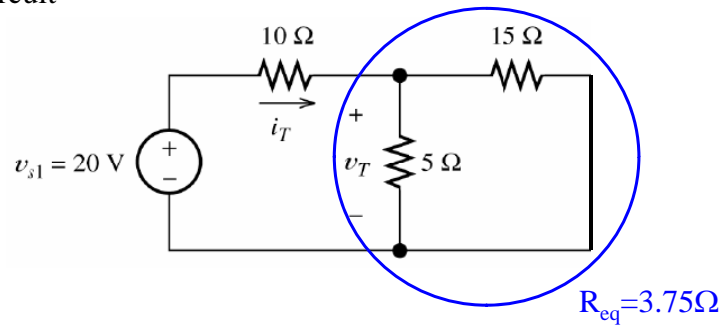

Figure 2.61 Circuit for Exercise 2.28.

ELECTRICAL ENGINEERING: PRINCIPLES AND APPLICATIONS, Fourth Edition, by Allan R. Hambley, ©2008 Pearson Education, Inc.

Circuit with just v_{s1}

v_{s2} short circuit



$$v_{T1} = \frac{R_{eq}}{R_{eq} + 10} v_{s1} = \frac{3.75}{3.75 + 10} 20 = 5.45V$$

ELECTRICAL ENGINEERING: PRINCIPLES AND APPLICATIONS, Fourth Edition, by Allan R. Hambley, ©2008 Pearson Education, Inc.

Circuit with just v_{s2}

v_{s1} short circuit

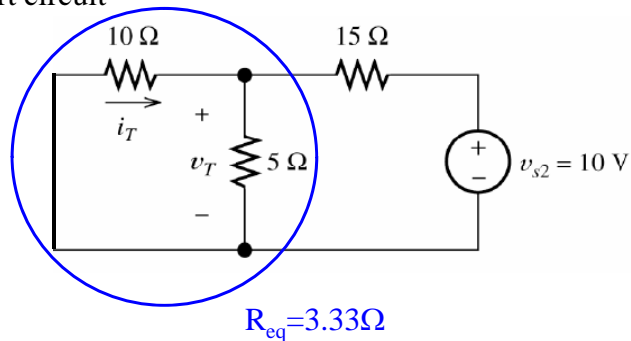

$$v_{T2} = \frac{R_{eq}}{R_{eq} + 15} v_{s2} = \frac{3.33}{3.33 + 15} 10 = 1.82V$$

$$v_T = v_{T1} + v_{T2} = 5.45 + 1.82 = 7.27V$$

ELECTRICAL ENGINEERING: PRINCIPLES AND APPLICATIONS, Fourth Edition, by Allan R. Hambley, ©2008 Pearson Education, Inc.

Superposition Principle

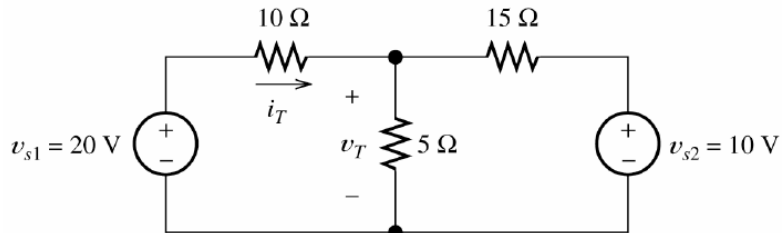

$$i_T = \frac{v_{s1} - v_T}{10\Omega} = \frac{20V - 7.27V}{10\Omega} = 1.27A$$

ELECTRICAL ENGINEERING: PRINCIPLES AND APPLICATIONS, Fourth Edition, by Allan R. Hambley, ©2008 Pearson Education, Inc.

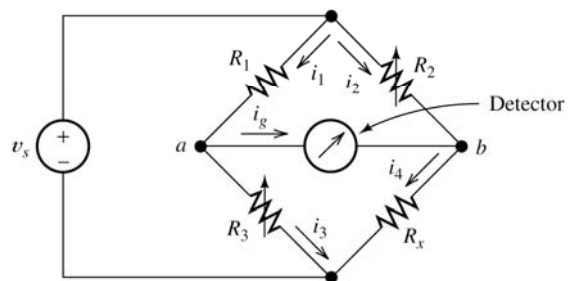

Figure 2.62 The Wheatstone bridge. When the Wheatstone bridge is balanced, $i_g = 0$ and $v_{ab} = 0$.

ELECTRICAL ENGINEERING: PRINCIPLES AND APPLICATIONS, Fourth Edition, by Allan R. Hambley, ©2008 Pearson Education, Inc.

WHEATSTONE BRIDGE

The Wheatstone bridge is used by mechanical and civil engineers to measure the resistances of strain gauges in experimental stress studies of machines and buildings.

$$R_x = \frac{R_2}{R_1} R_3$$

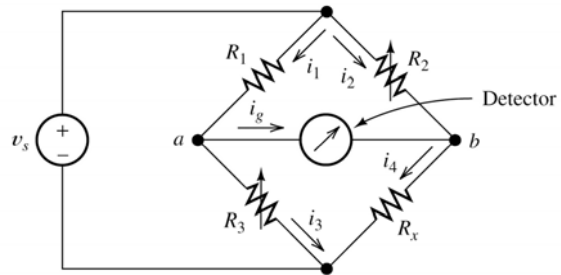

ELECTRICAL ENGINEERING: PRINCIPLES AND APPLICATIONS, Fourth Edition, by Allan R. Hambley, ©2008 Pearson Education, Inc.